



Intellectual Property Rights in Hungary

Hungarian IP Office in the Innovation Ecosystem

Fulbright Specialist Program, 13th May 2019

Dénes LEGEZA PhD

Head, Copyright Administration Unit
Hungarian Intellectual Property Office



I. IP rights in a chocolate nutshell

Case of Willy Wonka



What did he do?



How could we help him?

A trademark protects brand names and logos used on goods and services



86536780

CHARLIE AND THE CHOCOLATE FACTORY

183684



007049265



85488373



622181



85664626



Industrial design rights protect the appearance of a product, which results from attributes such as its shape, colors or materials



EM 004888501-0001 (D)

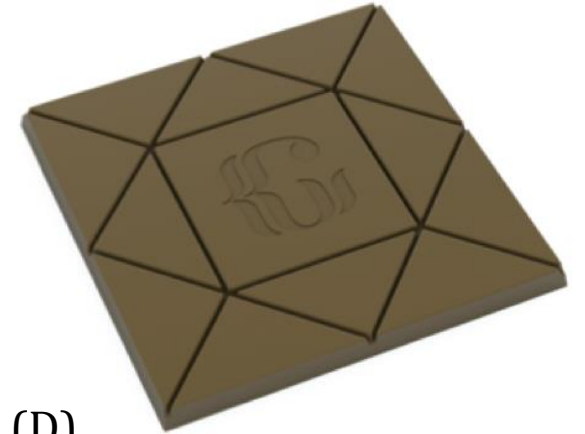

HIPO

003712959-0028 (D)

91318 (D)



A patent gives its owner the right to exclude others from making, using, selling, and importing an invention

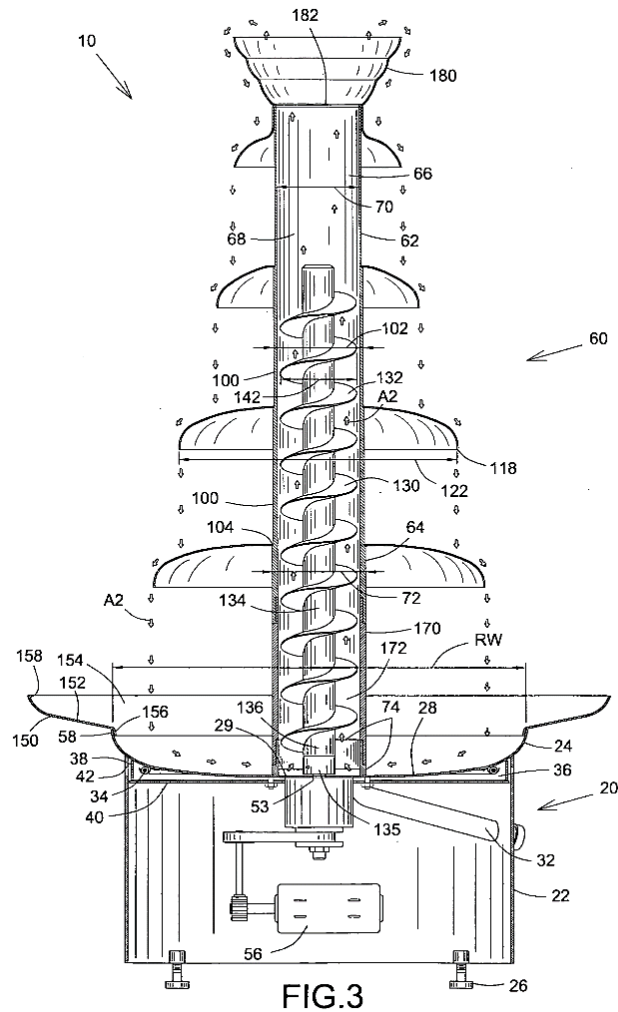

U.S. Patent Jun. 18, 2002 Sheet 1 of 7 US 6,406,733 B1

FIG. 1A

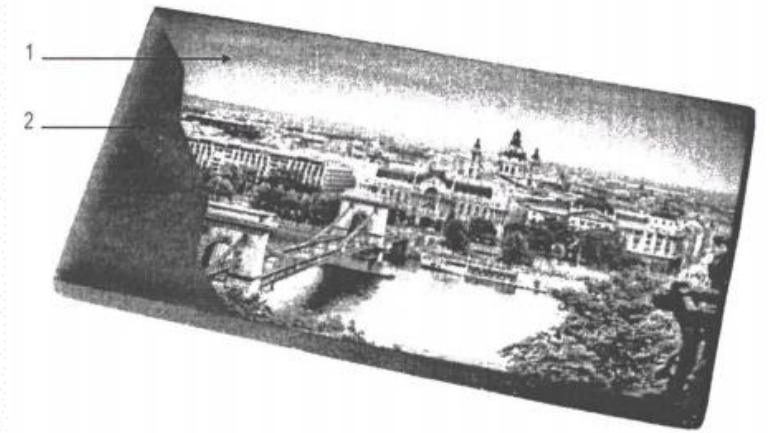
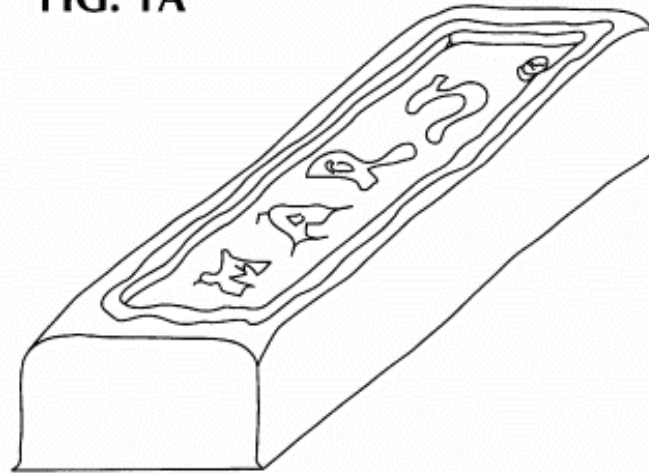

**Chocolate fountain
US20060081720A1**

Graphical labeled sweets
and a method for making them - P1600032

Copyright protects original literary, scientific and artistic works

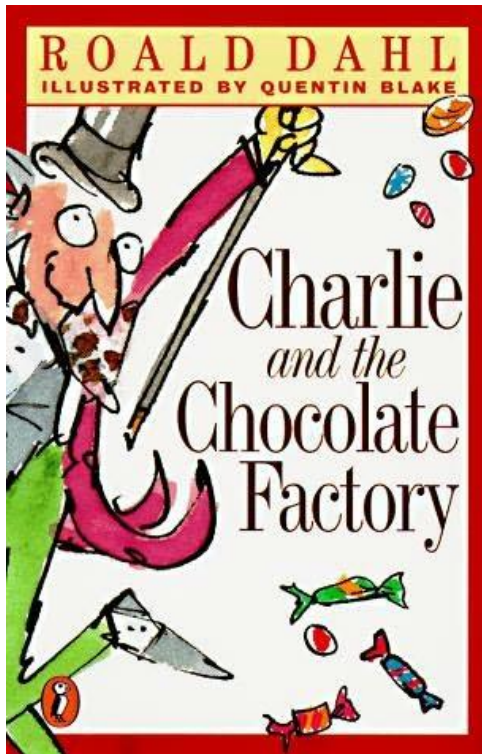

Book publishing

HIPO

Merchandising rights

Well managed intellectual property rights can provide competitive advantage to everyone who is involved in the value chain

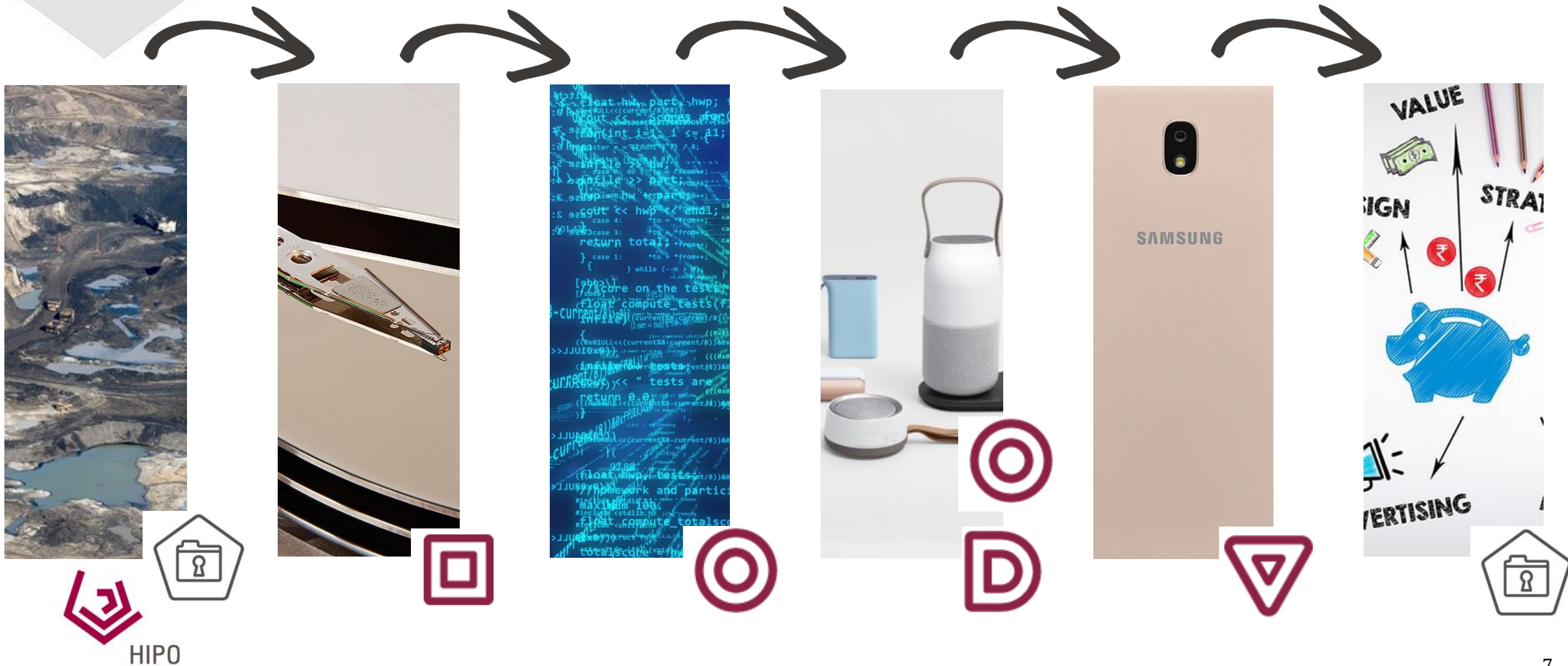

Value of IPRs in numbers

COMPONENTS *of* S&P 500 MARKET VALUE



II. Hungarian Intellectual Property Office

- It is a Government Office responsible for the protection of IP.
- Supervised by the Minister of Innovation and Technology.
- Its role is to **stimulate the innovation-based economy** through its tailor-made and high-quality official activities and services.

Competences of HIPO

- Examinations and procedures in the field of **industrial property**;
- Tasks in connection with **copyright and related rights**;
- Central governmental **information and documentation activities** in the field of IP; participation in the preparation of **IP legislation**;
- Preparation and implementation of the **Government's strategy for the protection of IP**;
- International and European co-operation in the field of IP protection;
- Performance of official and expert tasks relating to the **assessment of research and development activity**
- registration tasks related to the **tax base reduction benefit that may be claimed by enterprises supporting start-up enterprises.**



Main task of the HIPO: Granting rights



Inventions



Julius-K9
New technical solutions



Brand names, logos



artisjus



|| mahasz

CMOs, voluntary registry of works, orphan works



Designs, GUI

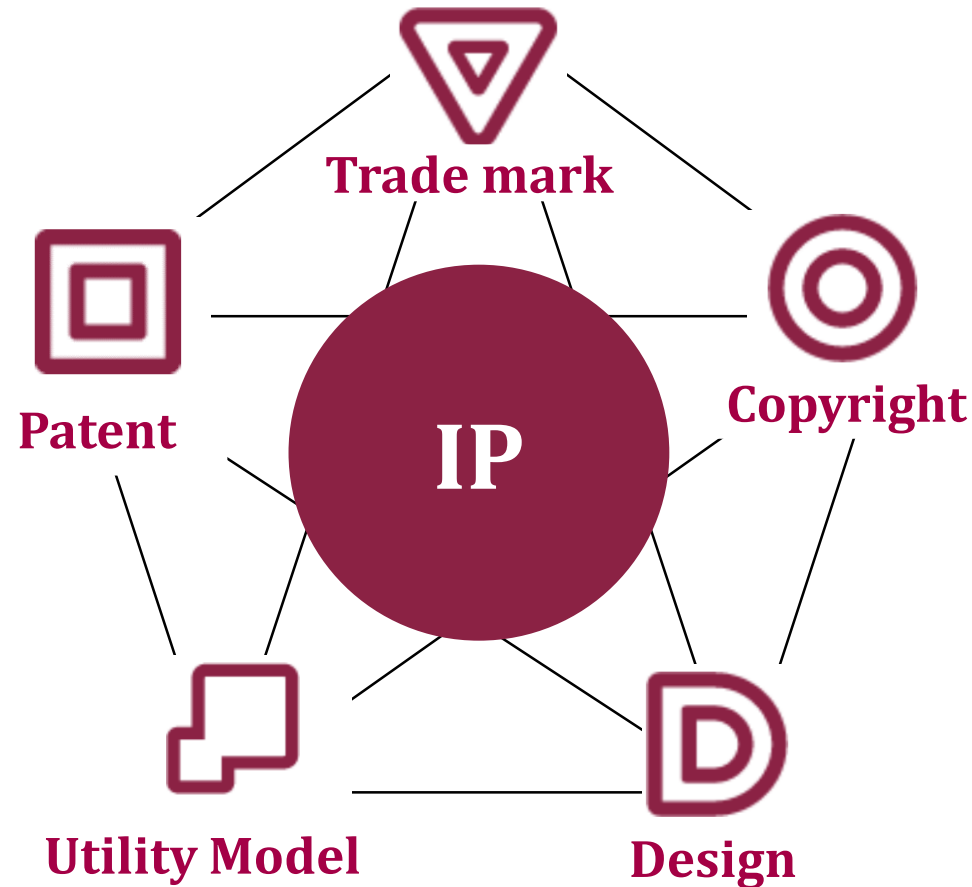

Further Services of HIPO

Patent

- Novelty search
- Novelty search with preliminary patentability report
- Preliminary Patentability report
- Validity search
- Freedom to operate (FTO) search

Let's visit our webpage

<http://www.sztnh.gov.hu>



HIPO

Trade mark

- Trade mark monitoring

Expert opinions / ADR

- Board of Experts on Industrial Property
- Board of Experts on Copyright

Intellectual Property Diagnoses (IPD)

Register of start-ups and angel inventor companies

III. Knowledge dissemination tasks

- **programs for promoting intellectual creative and innovative activities;**
- **launch, organize or promote competitions, exhibitions and other programs related to intellectual creative activity and intellectual property protection;**
- **disseminate knowledge related to IP protection, develop industrial property culture, enrich industrial property and copyright knowledge of enterprises** – in particular the small and medium-sized ones – by means of information, customer and advisory service, counselling and by other means,
- **promote the respect for intellectual property rights;**
- **supervise intellectual property training** outside public school system, operate its system.

Disseminate knowledge to

- Small and medium enterprises in the creative industry
- Start-up companies (Startup Safari 2018 and 2019)
- Venture capitals (HIVENTURE, K&H Incubator)
- Chambers of Commerce, Lawyers (from September 2019) and Architects
- Technology Transfer Offices (TTO)
- Students, librarians, researchers etc.

Disseminate knowledge by (i)

IP courses

- Industrial property at 3 levels: basic (20 hours), intermediate (60 hours) and advanced (270 hours **starts September 2019**)
- Copyright courses at 2 levels: basic (20 hours) and intermediate (60 hours next: **starts September 2019**)

Specialized courses upon request

Ujvári Thesis Competition

- Competition for university students: presenting IP aspect of their research (Prize: 150 000 -100 000 HUF in each IP category)

János Freckay Special Library of HIPO

- It has (almost) everything in IP.
- <https://opac3.mszh.monguz.hu/search>

Disseminate knowledge by (ii)

Cooperation with Universities

- Teaching and knowledge support cooperation with 19 Hungarian science and applied science universities

Distance learning courses (HIPO, EPO, WIPO, EUIPO)

Publications

- IP Journal, text books and course books, publishing of expert opinions, economic analyses, etc.

New teaching methods

- Card/board games, IP walks, mind map etc.

Cooperation with Science and Applied Science Universities

We would like to cooperate with every Hungarian universities.

- Cooperation
- PatLib Centers

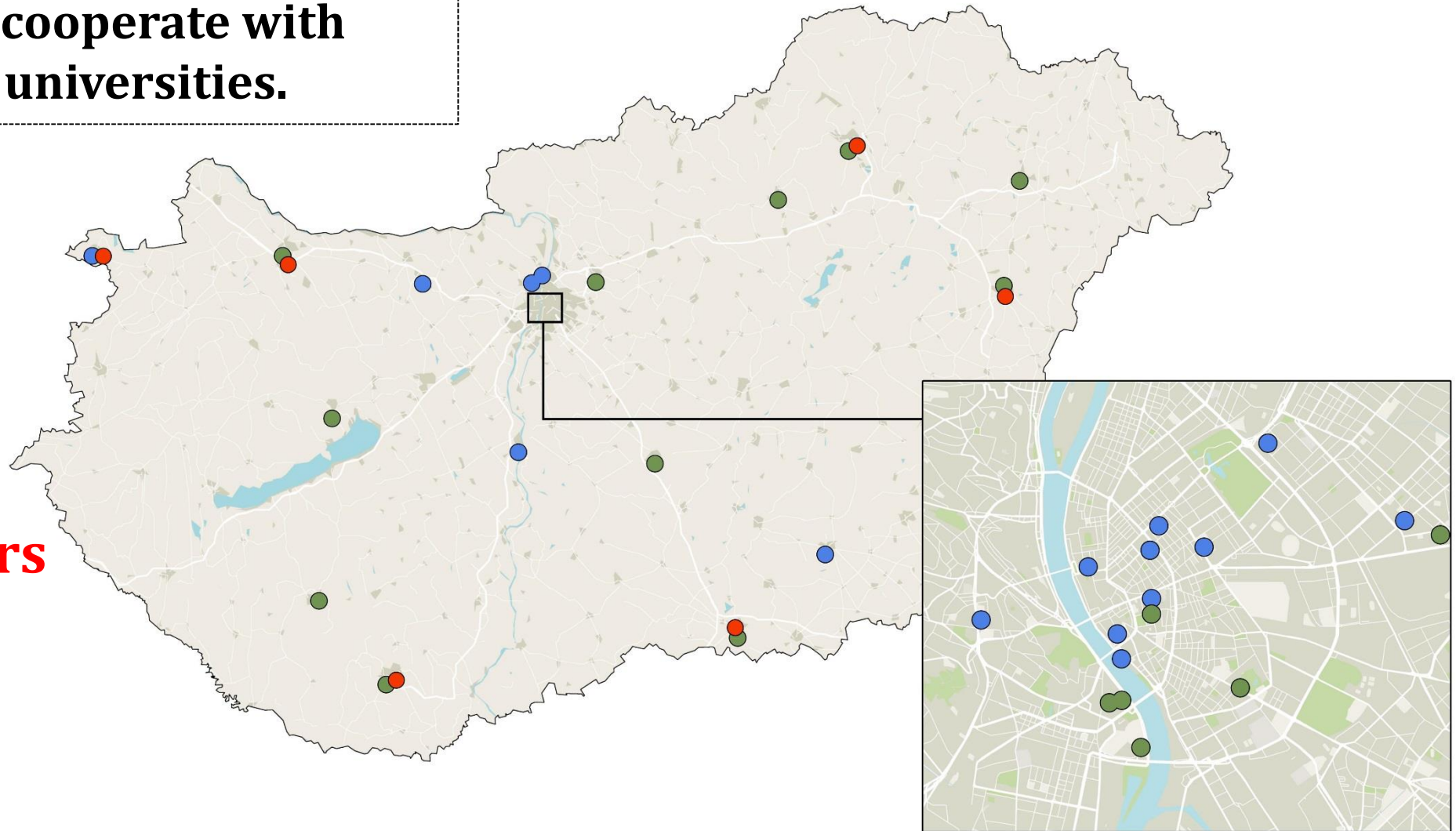

(Distance) Learning Courses

European Patent Academy



The European Patent Academy is the external education and training arm of the European Patent Office. Its mandate reflects the need to improve intellectual property training and education structures in Europe.

<p>Assessing clarity and unity of patent applications OD38-2019 <small>more info</small></p> <p>Yes Experienced 16 h 0 € 06.05.19</p>	<p>Assessing novelty and inventive step of patent applications - Video edition OD49-2017 <small>more info</small></p> <p>Yes Experienced 16 h 0 € Any time</p>
<p>Assessing novelty and inventive step of patent applications OD39-2019 <small>more info</small></p> <p>Yes Experienced 16 h 0 € 01.10.19</p>	<p>Business use of patent information <small>more info</small></p> <p>No Basic 4 h 0 € Any time</p>
<p>Catalogue of differing practises fiveIPoffices</p> <p>No Experienced 3 h 0 € Any time</p>	<p>Compulsory licensing in Europe <small>more info</small></p> <p>No Entry 20 h 0 € 11.01.19</p>

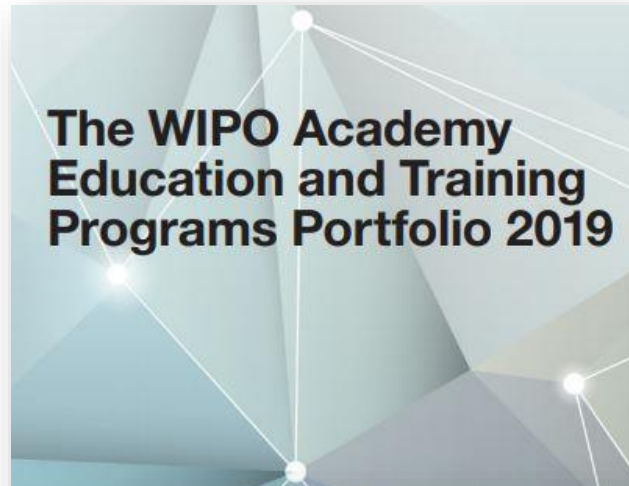

DL201E - DL-201 Copyright and Related Rights
DL203E - DL-203 Intellectual Property, Traditional Knowledge and Traditional Cultural Expressions
DL301OE - DL-301 Patents (Open)
DL302E - DL-302 Trademarks, Industrial Designs and Geographical Indications
DL317E - DL-317 Arbitration and Mediation Procedure under the WIPO Rules
DL318E - DL-318 Patent Information Search
DL320E - DL-320 Basics of Patent Drafting
DL450E - DL-450 Intellectual Property Management



≡ New courses

Programme Management Basics

Decisions of the Trimester of the EUIPO Boards of Appeal 2019

The significance of the 'Socialistic Brands' within the Trade Mark

Money Laundering and Copyright Piracy

Personal Data in the EUIPO Trade Mark and Design Tasks

Generic trade marks

IP and Sport

EDB Interesting Case Features

Publications

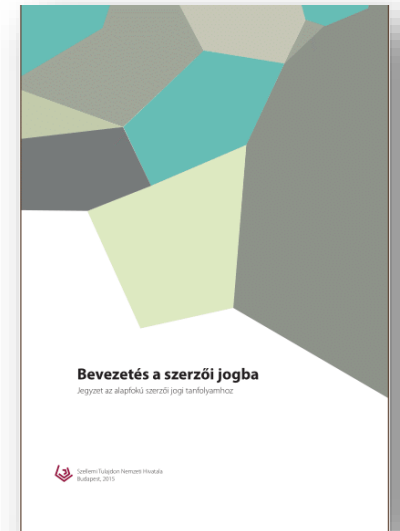
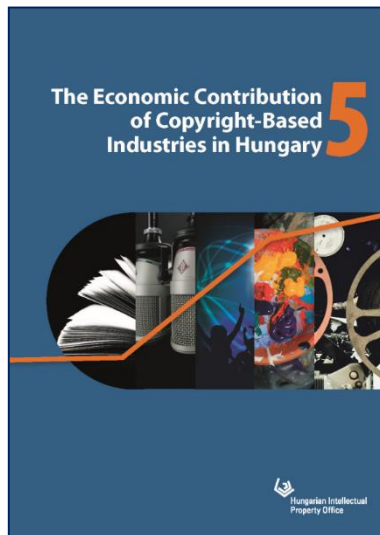
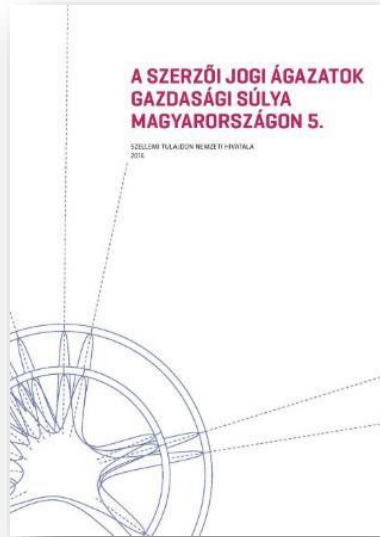
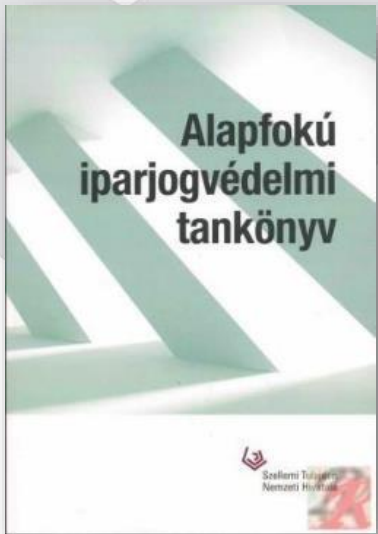

Copyright for everyone



HIPO

5. A SZERZŐ ÉS A SZERZŐI JOG EGYÉB JOGOSULTIAI

6. A SZERZŐ JOGAI

Bemelési utasítás	Procedúra	Kimeneti eszköz
-------------------	-----------	-----------------

11.4.2.1.3. Nyilvánossághoz közvetítés

védelmét élvezték a Rocky filmsorozat főbb karakterei⁶⁵²

BERÉNY RÓBERT (1887-1953):
Modiano (1929)⁸⁰⁷

KISS ERNŐ (1898-?):
Nemcsak a mama kedvence (1936)⁸⁰⁸

Az Fttv.⁸⁰⁹ tiltja a tisztességtelen kereskedelmi gyakorlatot, különösen azt, amely megtévesztő vagy agresszív. A Médiatv.⁸¹⁰ általánosságban előírja, hogy a médiaszolgáltatásban közzétett reklám nem sértheti az emberi méltóságot, nem tartalmazhat és nem támogathat a nemet, fajt vagy etnikai származáson, nemzetiségen, valláson vagy világnézeti meggyőződésen, fizikai vagy szellemi fogyatékonyságon, életkoron vagy szexuális irányultságon alapuló hátrányos megkülönböztetést, és számos rendelkezést tartalmaz a kiskorúak védelmében.⁸¹¹ A Médiatv. és Sajtótv.⁸¹² rendelkezései értelmében vényköteles gyógyszer, dohánytermék, fegyver, lőszer, robbanóanyag és az állami adóhatóság engedélye nélkül szervezett szerencsejáték nem, alkoholtartalmú italok pedig csak szigorú feltételekkel rek-

⁸⁰⁶ Ptk. 6:175-176. §.
⁸⁰⁷ http://poster-auctioneer.com/images/products/192/poster_192016_z.jpg
⁸⁰⁸ http://magyartermekonline.hu/wp-content/uploads/2014/10/stuhmer.tibi_csoki_plakat.jpg

Card/board games, role plays and other teaching tools

- Myth vs Reality
- Client Service
- Rights managed by CMOs
- Using works: how to calculate CMOs' tariffs
- How to read the Copyright Act



Myth vs Reality

IP urban walking tours – Learning by walking

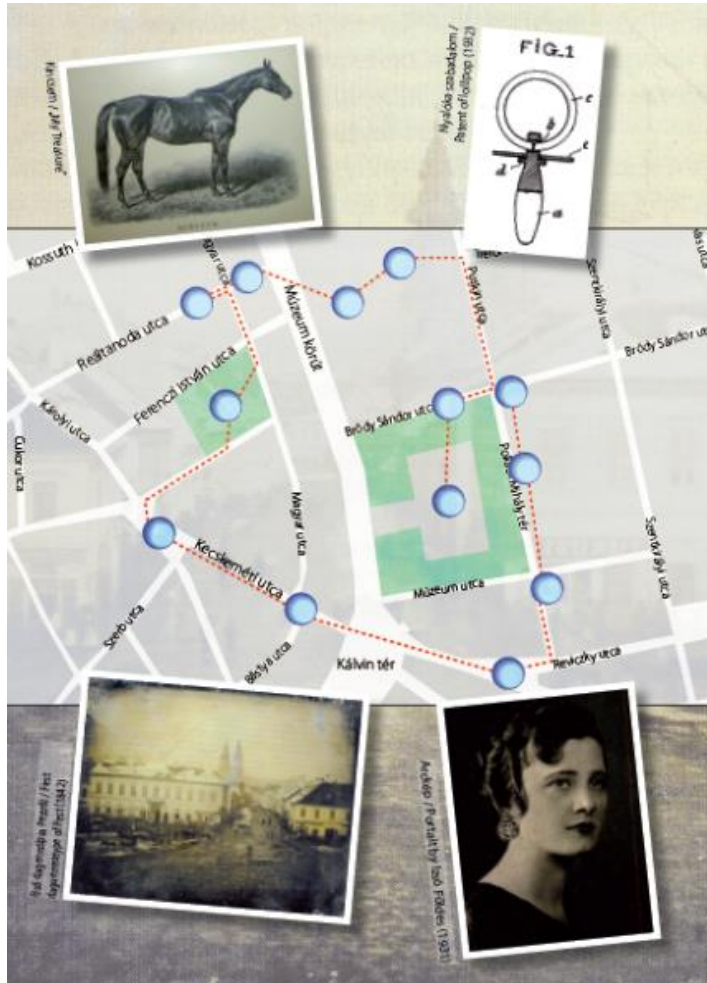

HEURÉKA! BUDAPEST

Városi séták a magyar alkotó szellem kincsei nyomában



Copyright mind map

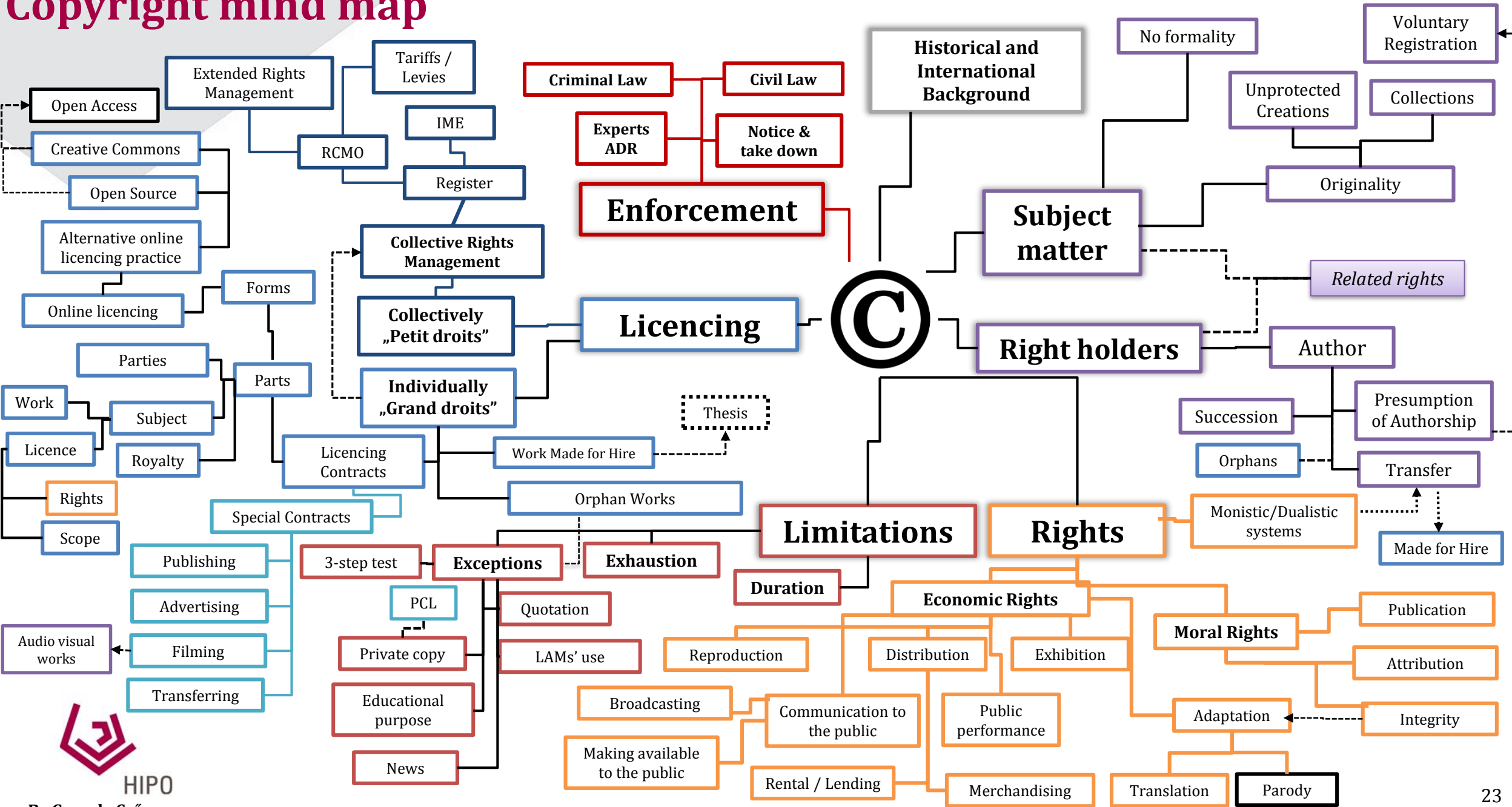

Summary: Idea or function itself cannot be protected, but there are plenty of legal instruments to protect our businesses and our clients.



**Idea
Problem
Function**



Product/Brand/Company name (R)

Product name / appearance (D) (R)

(P) (D) (C)

The diagram illustrates the legal protection of different aspects of a product. It shows a patent drawing of a person (FIG. 1) with a (P) symbol above it, followed by a plus sign, a blue puzzle piece with binary code (C) with a (C) symbol above it, and a screenshot of a Windows GUI (D, C) with (D) and (C) symbols above it. The entire diagram is enclosed in a green border.

“There are only two things in a business that make money – innovation and marketing, everything else is cost.”

Peter F. Drucker

“Intellectual Property is the oil of the 21st century.”

Mark Getty

Let's help creatives exploit this value!



Thank you for your attention!

Dénes Legeza

Hungarian Intellectual Property Office

denes.legeza@hipo.gov.hu

